



Rexon

Full Height Turnstiles & Full Height Gates



REXON FULL HEIGHT TURNSTILES

Our full height REXON turnstiles and gates are suited for indoor and outdoor access control applications in industrial entrances, sports arenas, construction sites and other facilities.

In order to achieve a high security turnstile solution without manned monitoring, the REXON turnstile range guarantees reliable operation in indoor and outdoor conditions.



REXON full height turnstiles come with a motorized drive unit which provides greater reliability, lower maintenance and faster throughput than the traditional mechanical and electromechanical units.

A powerful electromagnetic brake ensures complete protection against unauthorized passage.

BENEFITS

- Motor driven unit with a powerful electromagnetic brake
- Adaptable rotation speed barrier based on the passenger's movement
- Single and double versions for all projects
- Wide range of models including full height gates for wide passage lanes

CONTENTS

REXON		GATES	
4 - 5	REXON DEA 3 REXON DEA 3-U REXON DEA DUO 3	24 - 25	GATE DEA GATE DEA DUO GATE DEA-U GATE DEA DUO-U
6 - 7	REXON DEA 3 GATE-BIKE REXON DEA 3 GATE-BIKE-U	26 - 27	GATE ERA GATE ERA DUO GATE ERA-U GATE ERA DUO-U
8 - 9	REXON DEA 3 GATE-FULL REXON DEA 3 GATE-FULL-U	28 - 29	GATE ERA LE GATE ERA DUO LE GATE ERA LE-U GATE ERA DUO LE-U
10 - 11	REXON DEA 4 REXON DEA DUO 4	30 - 33	SPECIFICATION OVERVIEW
12 - 13	REXON ERA 3 REXON ERA DUO 3	34 - 35	OPTIONS & ACCESSORIES
14 - 15	REXON ERA 3 GS REXON ERA DUO 3 GS REXON ERA 3 GS-U		
16	REXON ERA 3 GATE-BIKE		
17	REXON ERA 4		
18 - 19	REXON ERA 4-LE REXON ERA DUO 4-LE		
20 - 21	REXON GLASS 1600 REXON GLASS 1800		
22	REXON BASIC 3		



REXON DEA 3 REXON DEA 3-U REXON DEA DUO 3

Type

REXON DEA 3
REXON DEA DUO 3
REXON DEA 3-U

Full height motorized turnstile with side panels and roof
3 door wings
Bi-directional passage

Drive Mechanism

Fail-Safe with Go Call function

Operating Environment

Outdoor
Indoor

Optional Accessories

Heel protector *
RFID reader bracket
Identification or Ticket terminal bracket
Access Light including bracket
Lane Light including bracket
Ceiling Light
USB convertor / Ethernet convertor
EasyTouch / TouchPanel
T-MON SW
Power supply backup
Alternative surface finishes
WAV Player

* Not available for version with U-shaped arms.

REXON DEA 3



REXON DEA 3-U



REXON DEA DUO 3



Barrier type	11 straight arms with black plastic covering caps \varnothing 40 mm / 1.57"	6 trombone style U-shaped arms \varnothing 22 mm / 0.87"	11 straight arms with black plastic covering caps \varnothing 40 mm / 1.57"
Unit height	2 465 mm / 97.05"	2 465 mm / 97.05"	2 465 mm / 97.05"
Unit width	1 400 mm / 55.12"	1 400 mm / 55.12"	2 520 mm / 99.20"
Passage height	2 100 mm / 82.68"	2 100 mm / 82.68"	2 100 mm / 82.68"
Passage width	620 mm / 24.41"	620 mm / 24.41"	620 mm / 24.41"
Casework	hot-dip zinc galvanized, powder coated finish in RAL colour per specs	hot-dip zinc galvanized, powder coated finish in RAL colour per specs	hot-dip zinc galvanized, powder coated finish in RAL colour per specs
Barrier	hot-dip zinc galvanized	hot-dip zinc galvanized	polished stainless steel

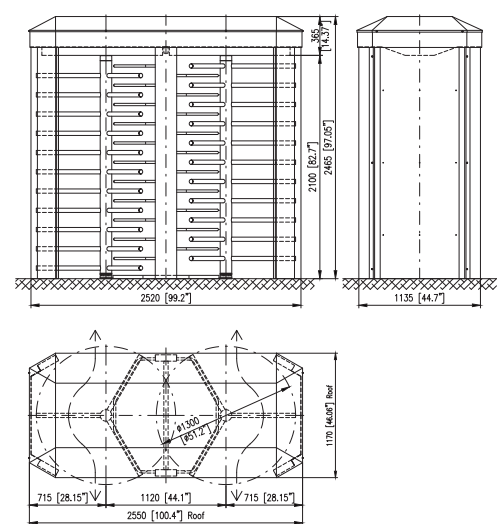
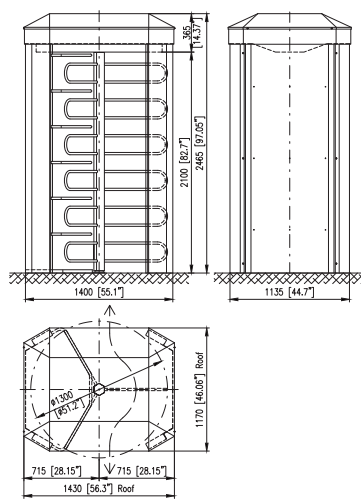
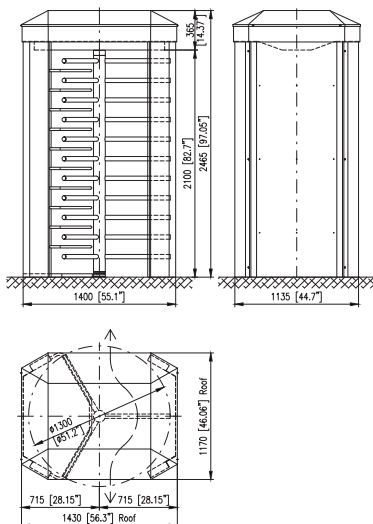



REXON DEA 3 GATE-BIKE REXON DEA 3 GATE-BIKE-U

Type

REXON DEA 3 GATE-BIKE
REXON DEA 3 GATE-BIKE-U

Full height motorized turnstiles with integrated bicycle gate
3 door wings
Bi-directional

Drive Mechanism

Fail-Safe with Go Call function

Operating Environment

Outdoor
Indoor

Optional Accessories

Induction loop system for detection of bicycles and scooters
Heel protector *
RFID reader bracket
Identification or Ticket terminal bracket
Access Light including bracket
Lane Light including bracket
Ceiling Light
USB convertor / Ethernet convertor
EasyTouch / TouchPanel
T-MON SW
Power supply backup
Alternative surface finishes
WAV Player

* Not available for version with U-shaped arms.

REXON DEA 3 GATE-BIKE



Barrier type	11 straight arms with black plastic covering caps \varnothing 40 mm / 1.57"
Unit height	2 465 mm / 97.05"
Unit width	2 330 mm / 91.73"
Unit width for scooters	2 520 mm / 99.21"
Passage height	2 100 mm / 82.68"
Passage width	620 mm / 24.41"
Passage width for bicycles	540 mm / 21.25"
Passage width for scooters	730 mm / 28.74"
Casework	hot-dip zinc galvanized, powder coated finish in RAL colour zinc specs
Barrier	hot-dip zinc galvanized

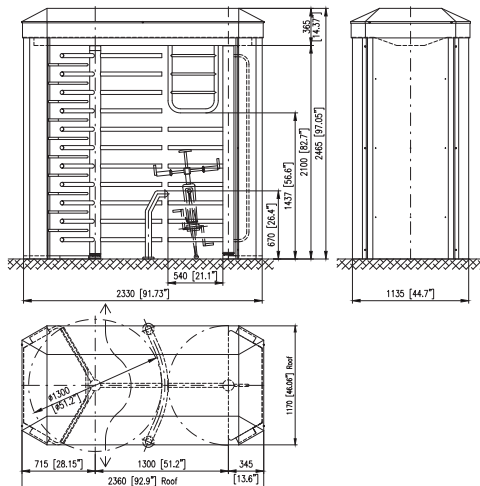

REXON DEA 3 GATE-BIKE-U



Barrier type	6 trombone style (U-shaped) arms \varnothing 22 mm / 0.87"
Unit height	2 465 mm / 97.05"
Unit width	2 330 mm / 91.73"
Unit width for scooters	2 520 mm / 99.21"
Passage height	2 100 mm / 82.68"
Passage width	620 mm / 24.41"
Passage width for bicycles	540 mm / 21.25"
Passage width for scooters	730 mm / 28.74"
Casework	hot-dip zinc galvanized, powder coated finish in RAL colour zinc specs
Barrier	polished stainless steel

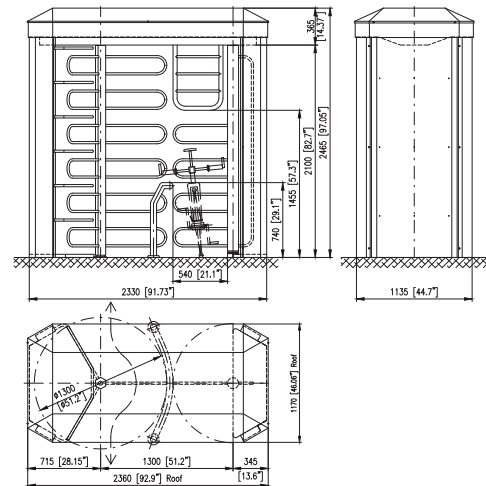



REXON DEA 3 GATE-FULL REXON DEA 3 GATE-FULL-U

Type

REXON DEA 3 GATE-FULL
REXON DEA 3 GATE-FULL-U

Full height motorized turnstile with integrated full-height gate
3 door wings
Bi-directional

Drive Mechanism

Fail-Safe with Go Call function

Operating Environment

Outdoor
Indoor

Optional Accessories

Heel protector *
RFID reader bracket
Identification or Ticket terminal bracket
Access Light including bracket
Lane Light including bracket
Ceiling Light
USB convertor / Ethernet convertor
EasyTouch / TouchPanel
T-MON SW
Power supply backup
Alternative surface finishes
WAV Player

* Not available for version with U-shaped arms.

REXON DEA 3 GATE-FULL



Barrier type	11 straight arms with black plastic covering caps \varnothing 40 mm / 1.57"
Unit height	2 465 mm / 97.05"
Unit width	2 590 mm / 101.97"
Passage height	2 100 mm / 82.68"
Passage width	620 mm / 24.41"
Passage width of gate	standard 800 mm / 31.49"
Passage width of gate	maximum 900 mm / 35.43"
Casework	hot-dip zinc galvanized, powder coated finish in RAL colour zinc specs
Barrier	hot-dip zinc galvanized

REXON DEA 3 GATE-FULL-U



Barrier type	6 trombone style (U-shaped) arms \varnothing 22 mm / 0.87"
Unit height	2 465 mm / 97.05"
Unit width	2 590 mm / 101.97"
Passage height	2 100 mm / 82.68"
Passage width	620 mm / 24.41"
Passage width of gate	standard 800 mm / 31.49"
Passage width of gate	maximum 900 mm / 35.43"
Casework	hot-dip zinc galvanized, powder coated finish in RAL colour zinc specs
Barrier	polished stainless steel

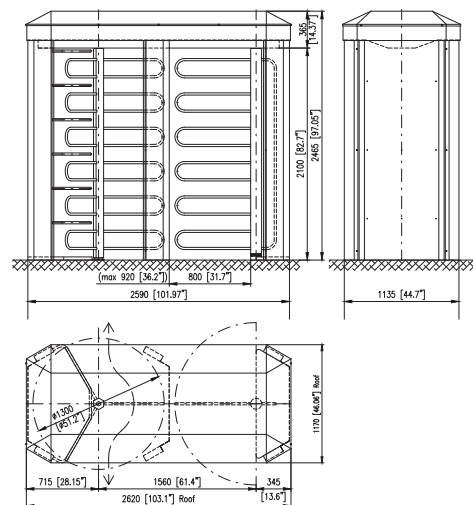
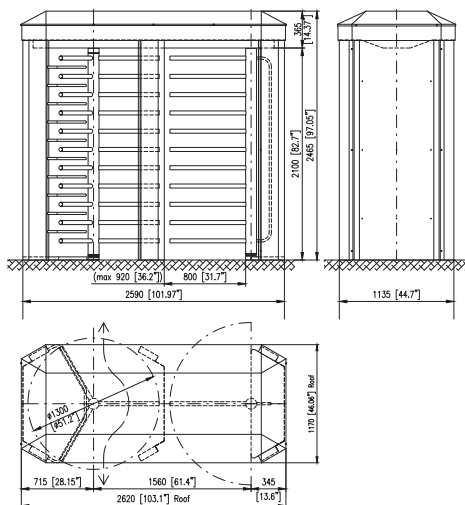



REXON DEA 4 REXON DEA DUO 4

Type

REXON DEA 4
REXON DEA DUO 4

Full height motorized turnstile
4 door wings
Bi-directional

Drive Mechanism

Fail-Safe with Go Call function

Operating Environment

Outdoor
Indoor

Optional Accessories

Heel protector
RFID reader bracket
Identification or Ticket terminal bracket
Access Light including bracket
Lane Light including bracket
Ceiling Light
USB convertor / Ethernet convertor
EasyTouch / TouchPanel
T-MON SW
Power supply backup
Alternative surface finishes
WAV Player

REXON DEA 4



Barrier type	11 straight arms with black plastic covering caps \varnothing 40 mm / 1.57"
Unit height	2 550 mm / 100.39"
Unit width	1 440 mm / 56.69"
Passage height	2 100 mm / 82.68"
Passage width	550 mm / 21.65"
Casework	stainless steel AISI 304 brushed finish
Barrier	stainless steel AISI 304 brushed finish

REXON DEA DUO 4



Barrier type	11 straight arms with black plastic covering caps \varnothing 40 mm / 1.57"
Unit height	2 550 mm / 100.39"
Unit width	2 235 mm / 88.00"
Passage height	2 100 mm / 82.68"
Passage width	550 mm / 21.65"
Casework	stainless steel AISI 304 brushed finish
Barrier	stainless steel AISI 304 brushed finish

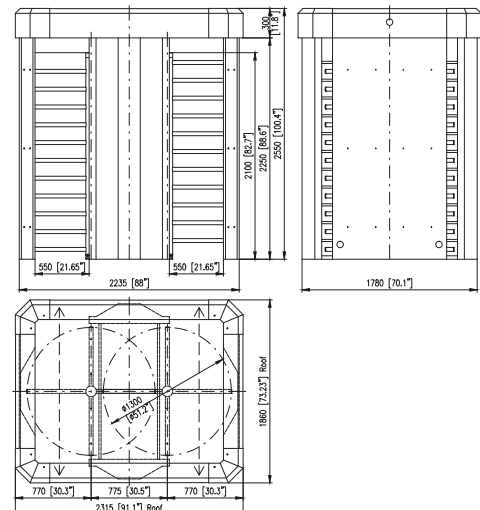
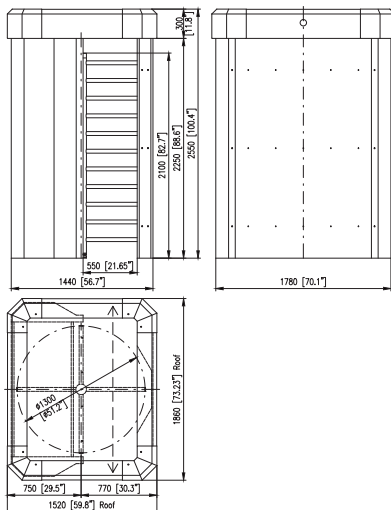



REXON ERA REXON ERA DUO 3

Type

REXON ERA 3
REXON ERA DUO 3

Full-height motorized turnstile
3 door wings
Bi-directional passage

Drive Mechanism

Fail-Safe with Go Call function

Operating Environment

Outdoor
Extreme outdoor *
Indoor

Optional Accessories

Heel protector
RFID reader bracket
Identification or Ticket terminal bracket
Access Light including bracket
Lane Light including bracket
Ceiling Light
Canopy LT
USB convertor / Ethernet convertor
EasyTouch / TouchPanel
T-MON SW
Power supply backup
Alternative surface finishes
WAV Player

* As an option

REXON ERA 3



REXON ERA DUO 3



Barrier type	11 straight arms with black plastic covering caps \varnothing 40 mm / 1.57"
Unit height	2 520 mm / 99.21"
Unit width	1 540 mm / 60.63"
Passage height	2 100 mm / 82.68"
Passage width	644 mm / 25.35"
Frame	hot-dip zinc galvanized
Top panel	hot-dip zinc galvanized, powder coated finish in RAL 7040
Barrier	hot-dip zinc galvanized

Barrier type	11 straight arms with black plastic covering caps \varnothing 40 mm / 1.57"
Unit height	2 520 mm / 99.21"
Unit width	2 360 mm / 92.91"
Passage height	2 100 mm / 82.68"
Passage width	644 mm / 25.35"
Frame	hot-dip zinc galvanized
Top panel	hot-dip zinc galvanized, powder coated finish in RAL 7040
Barrier	hot-dip zinc galvanized

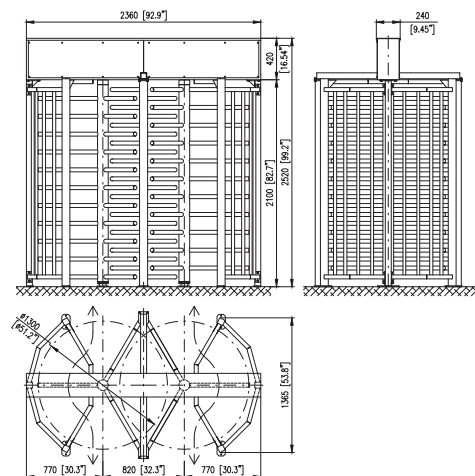
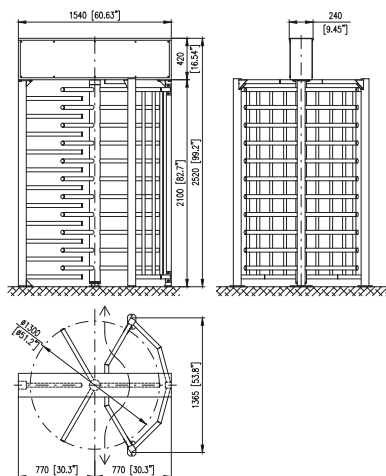



REXON ERA 3 GS

REXON ERA DUO 3 GS

REXON ERA 3 GS-U

Type

REXON ERA 3 GS
 REXON ERA DUO 3 GS
 REXON ERA 3 GS-U

Full-height motorized turnstile with side glass panels
 3 door wings
 Bi-directional

Drive Mechanism

Fail-Safe with Go Call function

Operating Environment

Outdoor
 Extreme outdoor **
 Indoor

Optional Accessories

Heel protector *
 RFID reader bracket
 Identification or Ticket terminal bracket
 Access Light including bracket
 Lane Light including bracket
 Ceiling Light
 Canopy LT
 USB convertor / Ethernet convertor
 EasyTouch / TouchPanel
 T-MON SW
 Power supply backup
 Alternative surface finishes
 WAV Player

* Not available for version with U-shaped arms. ** As an option

REXON ERA 3 GS

REXON ERA DUO 3 GS

REXON ERA 3 GS-U

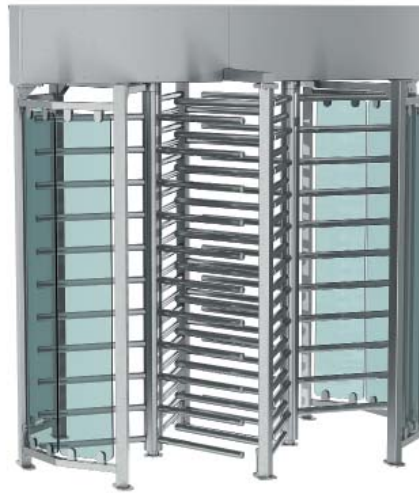

Barrier type	11 straight arms with black plastic covering caps \varnothing 40 mm / 1.57"	11 straight arms with black plastic covering caps \varnothing 40 mm / 1.57"	6 trombone style U-shaped arms \varnothing 22 mm / 0.87"
Unit height	2 520 mm / 99.21"	2 520 mm / 99.21"	2 520 mm / 99.21"
Unit width	1 540 mm / 60.63"	2 360 mm / 92.91"	1 540 mm / 60.63"
Passage height	2 100 mm / 82.68"	2 100 mm / 82.68"	2 100 mm / 82.68"
Passage width	644 mm / 25.35"	644 mm / 25.35"	644 mm / 25.35"
Frame	hot-dip zinc galvanized powder coated finish in RAL 7040	hot-dip zinc galvanized powder coated finish in RAL 7040	hot-dip zinc galvanized powder coated finish in RAL 7040
Top panel	hot-dip zinc galvanized	hot-dip zinc galvanized	hot-dip zinc galvanized
Barrier	hot-dip zinc galvanized	hot-dip zinc galvanized	polished stainless steel
Side panels	laminated glass	laminated glass	laminated glass

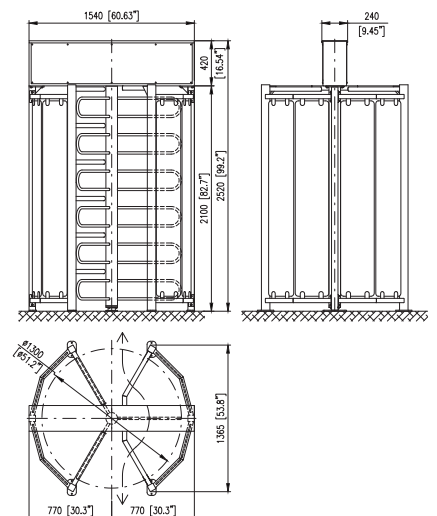
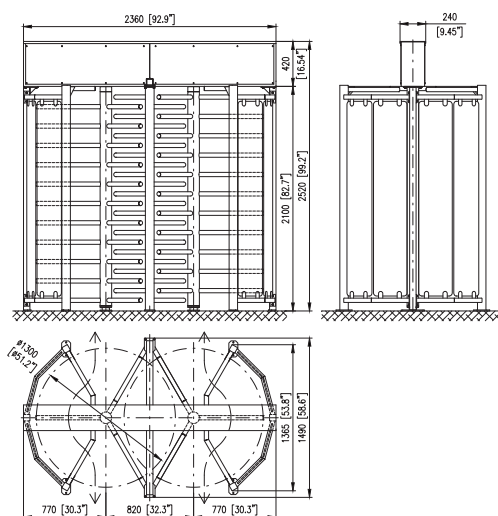
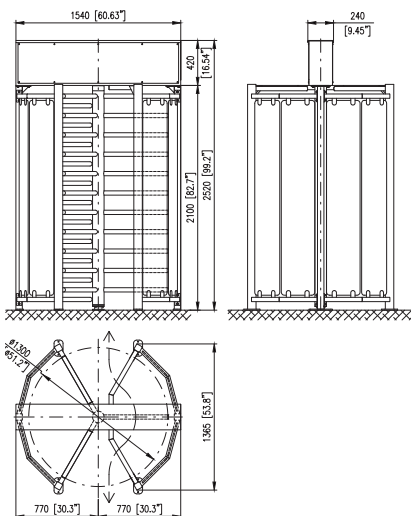



REXON ERA 3 GATE-BIKE

Type

REXON ERA 3 GATE-BIKE

Full height motorized turnstile with integrated bicycle gate
3 door wings
Bi-directional

Drive Mechanism

Fail-Safe with Go Call function

Operating Environment

Outdoor
Extreme outdoor *
Indoor

Optional Accessories

Induction loop system for detection of bicycles and scooters
Heel protector
RFID reader bracket
Identification or Ticket terminal bracket
Access Light including bracket
Lane Light including bracket
Ceiling Light
Canopy LT
USB convertor / Ethernet convertor
EasyTouch / TouchPanel
T-MON SW
Power supply backup
Alternative surface finishes
WAV Player



Barrier type	11 straight arms with black plastic covering caps ø 40 mm / 1.57"
Unit height	2 520 mm / 9.21"
Unit width	2 230 mm / 87.80"
Unit width for scooters	2 520 mm / 99.21"
Passage height	2 100 mm / 82.68"
Passage width	644 mm / 25.35"
Passage width for bicycles	540 mm / 21.26"
Passage width for scooters	730 mm / 28.74"
Frame	hot-dip zinc galvanized
Top panel	hot-dip zinc galvanized, powder coated finish in RAL 7040
Barrier	hot-dip zinc galvanized

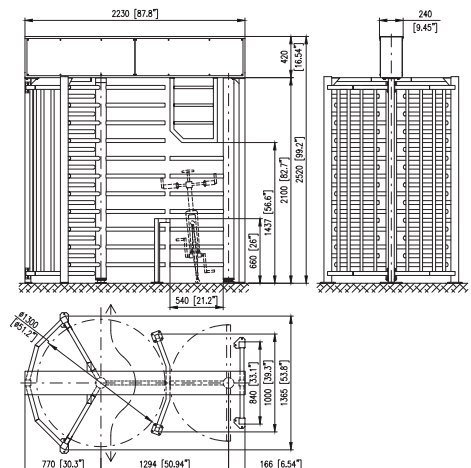

* As an option



REXON ERA 4

Type

REXON ERA 4

Full height motorized turnstile
4 door wings
Bi-directional

Drive Mechanism

Fail-Safe with Go Call function

Operating Environment

Outdoor
Extreme outdoor *
Indoor

Optional Accessories

Heel protector
RFID reader bracket
Identification or Ticket terminal bracket
Access Light including bracket
Lane Light including bracket
Ceiling Light
Canopy LT
USB convertor / Ethernet convertor
EasyTouch / TouchPanel
T-MON SW
Power supply backup
Alternative surface finishes
WAV Player



Barrier type	11 straight arms with black plastic covering caps \varnothing 40 mm / 1.57"
Unit height	2 520 mm / 99.21"
Unit width	1 540 mm / 60.63"
Passage height	2 100 mm / 82.68"
Passage width	535 mm / 21.06"
Frame	hot-dip zinc galvanized
Top panel	hot-dip zinc galvanized, powder coated finish in RAL 7040
Barrier	hot-dip zinc galvanized

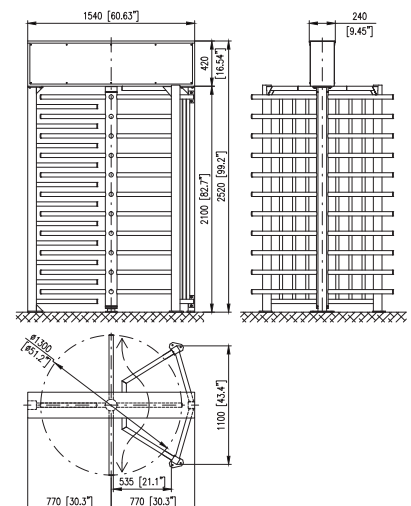

* As an option



REXON ERA 4-LE REXON ERA DUO 4-LE

Type

REXON ERA 4-LE
REXON ERA DUO 4-LE

Full height motorized turnstile with entry / exit side panels
4 door wings
Bi-directional

Drive Mechanism

Fail-Safe with Go Call function

Operating Environment

Outdoor
Extreme outdoor *
Indoor

Optional Accessories

Heel protector
RFID reader bracket
Identification or Ticket terminal bracket
Access Light including bracket
Lane Light including bracket
Ceiling Light
Canopy LT
USB convertor / Ethernet convertor
EasyTouch / TouchPanel
T-MON SW
Power supply backup
Alternative surface finishes
WAV Player

* As an option

REXON ERA 4-LE



Barrier type	11 straight arms with black plastic covering caps ø 40 mm / 1.57"
Unit height	2 520 mm / 99.21"
Unit width	1 350 mm / 53.15"
Passage height	2 100 mm / 82.68"
Passage width	550 mm / 21.63"
Frame	hot-dip zinc galvanized
Top panel	hot-dip zinc galvanized, powder coated finish in RAL 7040
Barrier	hot-dip zinc galvanized

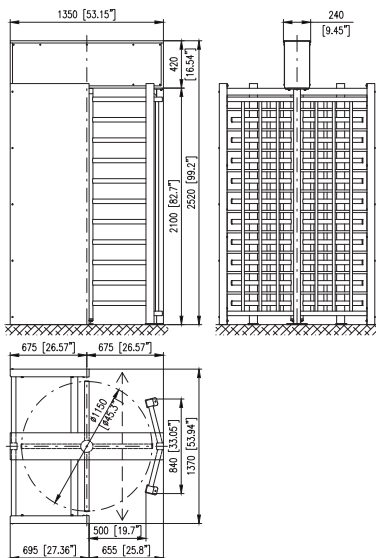

REXON ERA DUO 4-LE



Barrier type	11 straight arms with black plastic covering caps ø 40 mm / 1.57"
Unit height	2 520 mm / 99.21"
Unit width	2 050 mm / 80.71"
Passage height	2 100 mm / 82.68"
Passage width	550 mm / 21.63"
Frame	hot-dip zinc galvanized
Top panel	hot-dip zinc galvanized, powder coated finish in RAL 7040
Barrier	hot-dip zinc galvanized

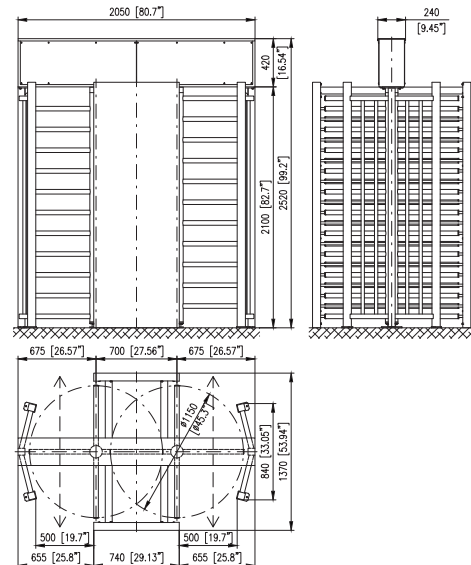



REXON GLASS 1600 / 1800

Type

REXON GLASS 1600
REXON GLASS 1800

Revolving glass full-height turnstile
3 door wings
Bi-directional

Drive Mechanism

Fail-Safe with Go Call function

Operating Environment

Indoor

Optional Accessories

Push-Bars on glass wing
RFID reader bracket
Identification or Ticket terminal bracket
Access Light including bracket
Lane Light including bracket
Ceiling Light
USB convertor / Ethernet convertor
EasyTouch / TouchPanel
T-MON SW
Power supply backup
Alternative surface finishes
WAV Player

REXON GLASS 1600



Barrier type	laminated glass
Unit height	2 450 mm / 96.46"
Unit width	1 610 mm / 63.39"
Passage height	2 050 mm / 82.68"
Passage width	705 mm / 27.76"
Frame	brushed stainless steel AISI 304
Top panel	brushed stainless steel AISI 304
Barrier	10 mm / 0.39" tempered laminated glass

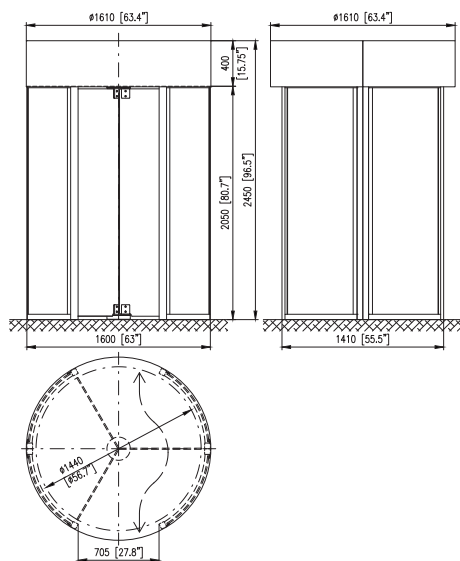

REXON GLASS 1800



Barrier type	laminated glass
Unit height	2 450 mm / 96.46"
Unit width	1 810 mm / 71.26"
Passage height	2 050 mm / 82.68"
Passage width	805 mm / 31.69"
Frame	brushed stainless steel AISI 304
Top panel	brushed stainless steel AISI 304
Barrier	10 mm / 0.39" tempered laminated glass

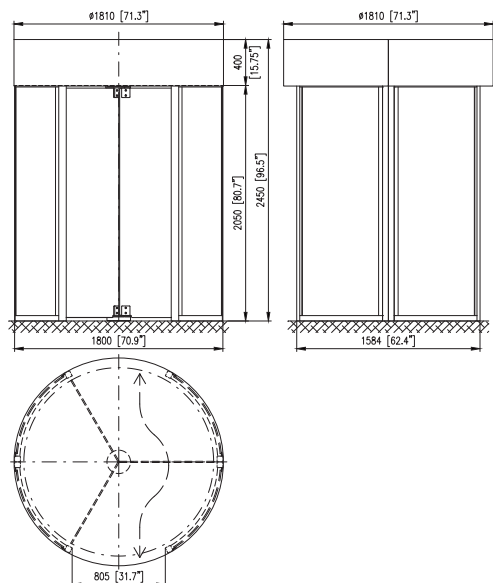



REXON BASIC 3

Type

REXON BASIC 3

Full-height motorized turnstile
3 door wings
Bi-directional

Drive Mechanism

Fail-Safe with Go Call function

Operating Environment

Outdoor
Indoor

Optional Accessories

Heel protector
RFID reader bracket
Identification or Ticket terminal bracket
Access Light including bracket
Lane Light including bracket
Ceiling Light
USB convertor / Ethernet convertor
EasyTouch / TouchPanel
T-MON SW
Power supply backup
Alternative surface finishes
WAV Player



Barrier type	8 straight arms with black plastic covering caps \varnothing 40 mm / 1.57"
Unit height	2 435 mm / 95.87"
Unit width	1 385 mm / 54.53"
Passage height	2 040 mm / 80.31"
Passage width	648 mm / 25.51"
Frame	hot-dip zinc galvanized
Top panel	hot-dip zinc galvanized
Barrier	hot-dip zinc galvanized

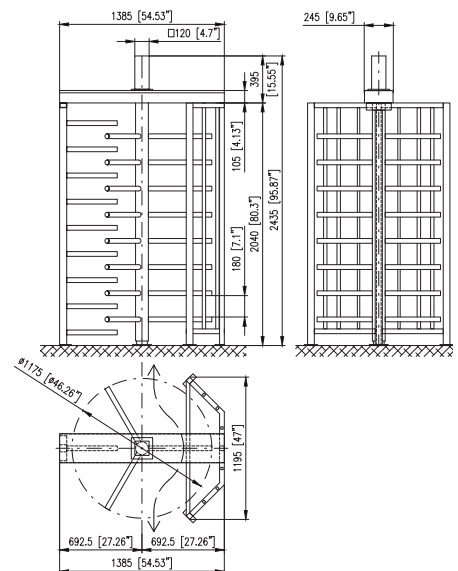



Gate

Full Height Gates



GATE DEA

GATE DEA DUO

GATE DEA-U

GATE DEA DUO-U

Type

GATE DEA
GATE DEA DUO
GATE DEA-U
GATE DEA DUO-U

Motorized full height gate
Gate door barrier
Bi-directional passage

Drive Mechanism

Fail-Safe

Operating Environment

Outdoor
Indoor

Optional Accessories

Heel protector *
RFID reader bracket
Identification or Ticket terminal bracket
Access Light including bracket
lane Light including bracket
Ceiling Light
USB convertor / Ethernet convertor
EasyTouch / TouchPanel
T-MON SW
Power supply backup
Alternative surface finishes

GATE DEA

GATE DEA DUO

Barrier type	11 straight arms with black plastic covering caps ø 40 mm / 1.57"	
Unit height	2 465 mm / 97.05"	2 465 mm / 97.05"
Unit width	1 450 mm / 57.09"	2 570 mm / 101.18"
Passage height	2 100 mm / 82.68"	2 100 mm / 82.68"
Passage width	max. 920 mm / 36.22"	max. 1 800 mm / 70.87"
Casework	hot-dip zinc galvanized, powder coated finish in RAL colour per specs	
Barrier	hot-dip zinc galvanized	

GATE DEA-U

GATE DEA DUO-U

Barrier type	6 trombone style (U-shaped) arms ø 22 mm / 0.87"	
Unit height	2 465 mm / 97.05"	2 465 mm / 97.05"
Unit width	1 450 mm / 57.09"	2 570 mm / 101.18"
Passage height	2 100 mm / 82.68"	2 100 mm / 82.68"
Passage width	max. 920 mm / 36.22"	max. 1 800 mm / 70.87"
Casework	hot-dip zinc galvanized, powder coated finish in RAL colour per specs	
Barrier	polished stainless steel	

* Not available for version with U-shaped arms.

GATE DEA

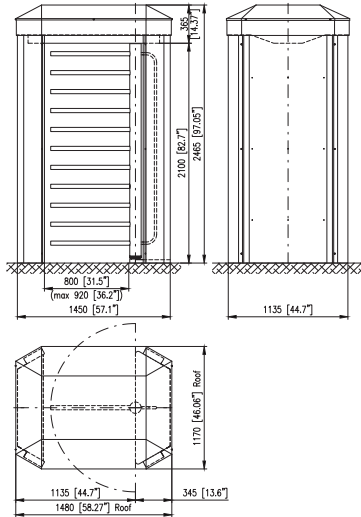

GATE DEA DUO

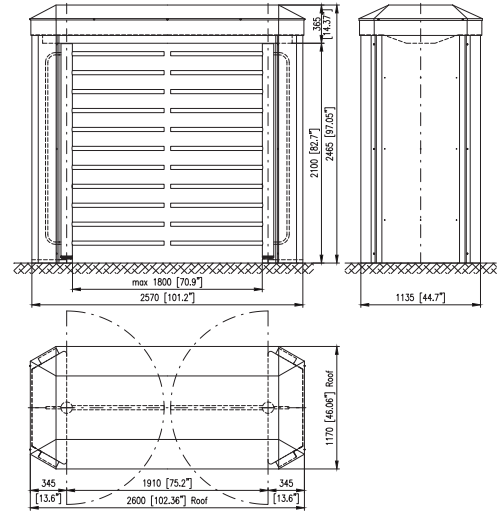

GATE DEA-U

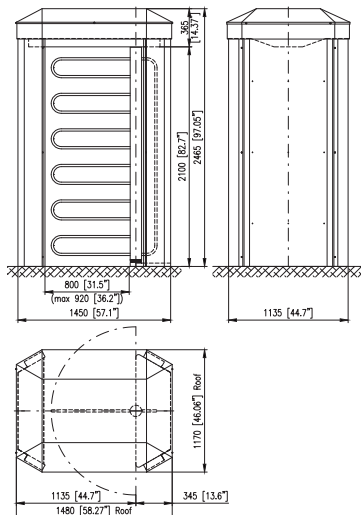

GATE DEA DUO-U

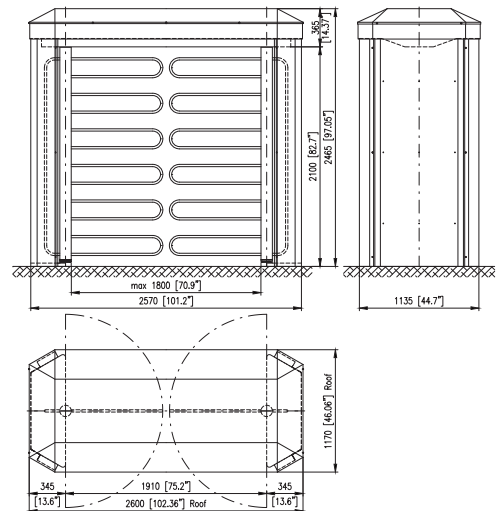



GATE ERA GATE ERA DUO GATE ERA-U GATE ERA DUO-U

Type

GATE ERA
GATE ERA DUO
GATE ERA-U
GATE ERA DUO-U

Motorized full height gate
Gate door barrier
Bi-directional passage

Drive Mechanism

Fail-Safe

Operating Environment

Outdoor / Extreme outdoor**
Indoor

Optional Accessories

Heel protector *
RFID reader bracket
Identification or Ticket terminal bracket
Access Light / Lane Light including bracket
Extreme outdoor package
Ceiling Light
Canopy LT
USB convertor / Ethernet convertor
EasyTouch / TouchPanel / T-MON SW
Power supply backup
Alternative surface finishes
WAV Player

GATE ERA

GATE ERA DUO

Barrier type	11 straight arms with black plastic covering caps ø 40 mm / 1.57"	
Unit height	2 520 mm / 99.21"	2 520 mm / 99.21"
Unit width	1 020 mm / 40.16"	2 090 mm / 82.28"
Passage height	2 100 mm / 82.68"	2 100 mm / 82.68"
Passage width	max. 920 mm / 36.22"	max. 1 800 mm / 70.87"
Frame	hot-dip zinc galvanized	
Top panel	hot-dip zinc galvanized, powder coated finish in RAL 7040	
Barrier	hot-dip zinc galvanized	

GATE ERA-U

GATE ERA DUO-U

Barrier type	6 trombone style (U-shaped) arms ø 22 mm / 0.87"	
Unit height	2 520 mm / 99.21"	2 520 mm / 99.21"
Unit width	1 020 mm / 40.16"	2 090 mm / 82.28"
Passage height	2 100 mm / 82.68"	2 100 mm / 82.68"
Passage width	max. 920 mm / 36.22"	max. 1 800 mm / 70.87"
Frame	hot-dip zinc galvanized	
Top panel	hot-dip zinc galvanized, powder coated finish in RAL 7040	
Barrier	polished stainless steel	

GATE ERA

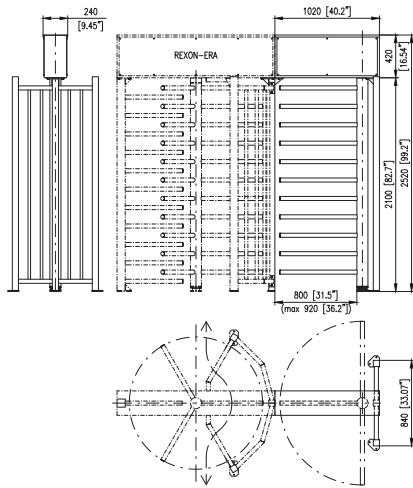

GATE ERA DUO

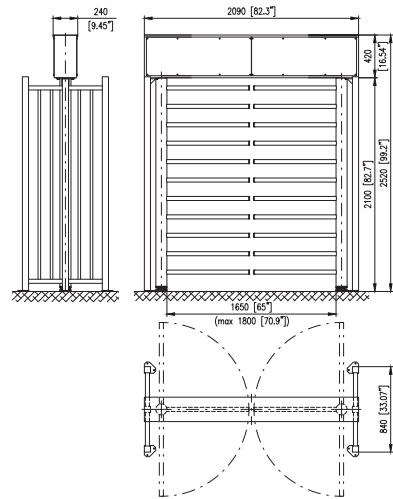

GATE ERA-U

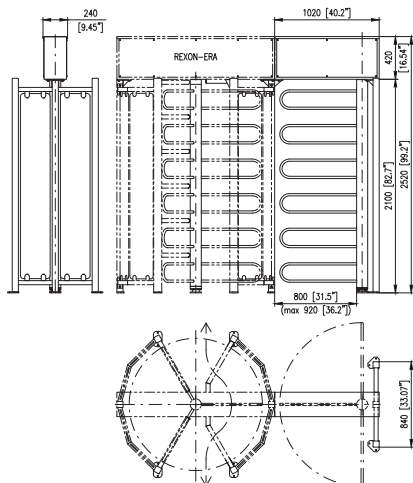

GATE ERA DUO-U

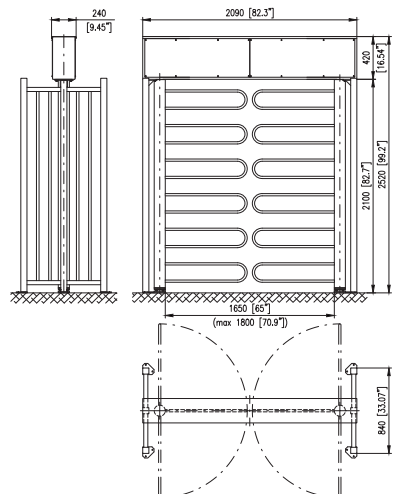



GATE ERA LE

GATE ERA DUO LE

GATE ERA LE-U

GATE ERA DUO LE-U

Type

GATE ERA LE
GATE ERA DUO LE
GATE ERA LE-U
GATE ERA DUO-LE-U

Motorized full height gate with entry/exit side panels
Gate door barrier
Bi-directional passage

Drive Mechanism

Fail-Safe

Operating Environment

Outdoor / Extreme outdoor**
Indoor

Optional Accessories

Heel protector*
RFID reader bracket
Identification or Ticket terminal bracket
Access Light / Lane Light including bracket
Extreme outdoor package
Ceiling Light
Canopy LT
USB convertor / Ethernet convertor
EasyTouch / TouchPanel / T-MON SW
Power supply backup
Alternative surface finishes
WAV Player

	GATE ERA LE	GATE ERA DUO LE
Barrier type	11 straight arms with black plastic covering caps ø 40 mm / 1.57"	
Unit height	2 520 mm / 99.21"	2 520 mm / 99.21"
Unit width	1 240 mm / 48.82"	2 410 mm / 94.88"
Passage height	2 100 mm / 82.68"	2 100 mm / 82.68"
Passage width	max. 920 mm / 36.22"	max 1 800 mm / 70.87"
Frame	hot-dip zinc galvanized	
Top panel	hot-dip zinc galvanized, powder coated finish in RAL 7040	
Barrier	hot-dip zinc galvanized	

	GATE ERA LE-U	GATE ERA DUO LE-U
Barrier type	6 trombone style (U-shaped) arms ø 22 mm / 0.87"	
Unit height	2 520 mm / 99.21"	2 520 mm / 99.21"
Unit width	1 240 mm / 48.82"	2 410 mm / 94.88"
Passage height	2 100 mm / 82.68"	2 100 mm / 82.68"
Passage width	max. 920 mm / 36.22"	max 1 800 mm / 70.87"
Frame	hot-dip zinc galvanized	
Top panel	hot-dip zinc galvanized, powder coated finish in RAL 7040	
Barrier	polished stainless steel	

* Not available for version with U-shaped arms. ** As an option

GATE ERA LE

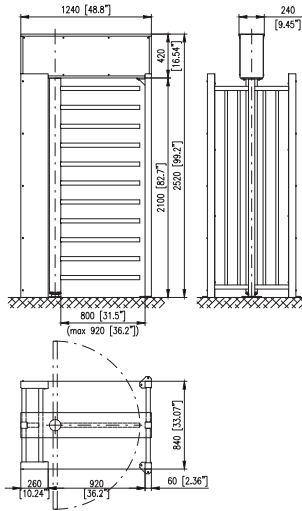

GATE ERA DUO LE

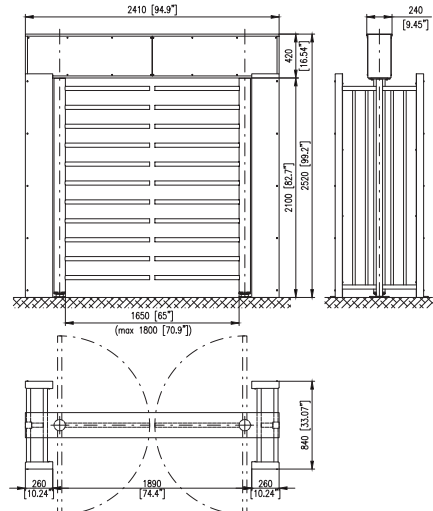

GATE ERA LE-U

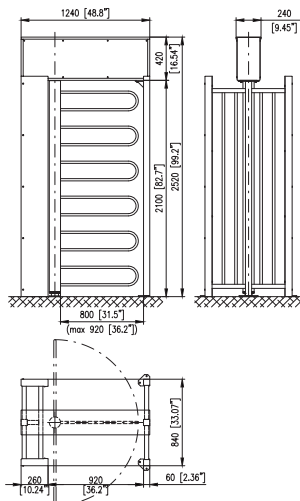

GATE ERA DUO LE-U

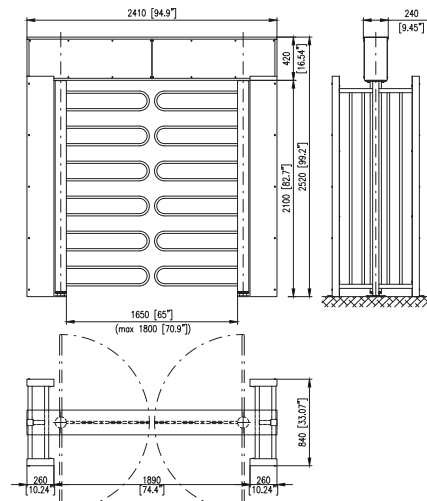

Turnstile Model REXON



	DEA 3	DEA 3-U	DEA DUO 3	DEA 3 GATE-BIKE	DEA 3 GATE-BIKE-U	DEA 3 GATE-FULL	DEA 3 GATE-FULL-U	DEA 4
Type								
Full-height motorized turnstile / Full-height motorized turnstile with side panels	- / •	- / •	- / •	- / •	- / •	- / •	- / •	- / •
Single version / Double version / Roof	• / - / •	• / - / •	- / • / •	• / - / •	• / - / •	• / - / •	• / - / •	• / - / •
Integrated bicycle gate / Integrated full-height gate	- / -	- / -	- / -	• / -	• / -	- / •	- / •	- / -
Barrier type								
3 doors barrier / 4 doors barrier	• / -	• / -	• / -	• / -	• / -	• / -	• / -	- / •
11 straight arms [1] / 6 trombone style (U-shaped) arms [2]	• / -	- / •	• / -	• / -	- / •	• / -	- / •	• / -
Dimensions								
Unit height in mm / inches	2 465 / 9705*	2 465 / 9705*	2 465 / 9705*	2 465 / 9705*	2 465 / 9705*	2 465 / 9705*	2 465 / 9705*	2 550 / 100.39*
Unit width in mm / inches	1 400 / 55.12*	1 400 / 55.12*	2 520 / 99.21*	2 330 / 91.73*	2 330 / 91.73*	2 590 / 101.97*	2 590 / 101.97*	1 440 / 56.69*
Passage height in mm / inches	2 100 / 82.68*	2 100 / 82.68*	2 100 / 82.68*	2 100 / 82.68*	2 100 / 82.68*	2 100 / 82.68*	2 100 / 82.68*	2 100 / 82.68*
Passage width in mm / inches	620 / 24.41*	620 / 24.41*	620 / 24.41*	620 / 24.41*	620 / 24.41*	620 / 24.41*	620 / 24.41*	550 / 21.65*
Passage width for bike or full-height gate in mm / inches [7]	-	-	-	540 / 21.26*	540 / 21.26*	900 / 35.43*	900 / 35.43*	-
Standard material								
ERA or Basic version - frame: hot dip zinc galvanized	-	-	-	-	-	-	-	-
DEA version - casework: hot dip zinc galvanized with RAL powder coated finish / stainless steel	• / -	• / -	• / -	• / -	• / -	• / -	• / -	- / •
GLASS version: stainless steel frame with glass side panels	-	-	-	-	-	-	-	-
Top panel or Roof: hot dip zinc galvanized with RAL powder coated finish / stainless steel	• / -	• / -	• / -	• / -	• / -	• / -	• / -	- / •
Barrier: hot dip zinc galvanized with plastic covering caps / polished stainless steel	• / -	- / •	• / -	• / -	- / •	• / -	- / •	- / •
Safety features								
Emergency (Fire Alarm) input / Go Call function	• / •	• / •	• / •	• / •	• / •	• / •	• / •	• / •
Induction loop system for detection of bicycles and scooters	-	-	-	•	•	-	-	-
Communication interface								
Relay Inputs / Outputs	• / •	• / •	• / •	• / •	• / •	• / •	• / •	• / •
RS485 / USB / Ethernet	• / • / •	• / • / •	• / • / •	• / • / •	• / • / •	• / • / •	• / • / •	• / • / •
Drive mechanism								
Fail-Safe [4]	•	•	•	•	•	•	•	•
Operating environment								
Indoor / Outdoor	• / •	• / •	• / •	• / •	• / •	• / •	• / •	• / •
Extreme weather conditions *	-	-	-	-	-	-	-	-
Power supply input								
24 VAC / 230 VAC [6]	• / •	• / •	• / •	• / •	• / •	• / •	• / •	• / •
Backup battery *	•	•	•	•	•	•	•	•
Optional features								
Heel protector	•	-	•	•	-	•	-	•
RFID reader bracket / Identification or Ticket terminal bracket	• / •	• / •	• / •	• / •	• / •	• / •	• / •	• / •
Access Light / Lane Light including bracket	• / •	• / •	• / •	• / •	• / •	• / •	• / •	• / •
Ceiling Light	•	•	•	•	•	•	•	•
Canopy LT	-	-	-	-	-	-	-	-
Optional remote control systems								
Remote control console (EasyTouch, TouchPanel)	•	•	•	•	•	•	•	•
TMON software application (remote control from any PC) / Passage Scheduler (automatic planner)	• / •	• / •	• / •	• / •	• / •	• / •	• / •	• / •
Optional finishes								
ERA or Basic version - frame and top panel: RAL powder coated finish / stainless steel	- / -	- / -	- / -	- / -	- / -	- / -	- / -	- / -
DEA version - casework and roof: stainless steel	•	•	•	•	•	•	•	•
Barrier: RAL powder coated finish / brushed stainless steel	• / •	[5]	• / •	• / •	[5]	• / •	[5]	• / •

• Available
- Not available

* Optional accessories
[1] Ø 40 mm / 1.57" with plastic covering caps

[2] Ø 22 mm / 0.87"
[3] 8 straight bars

[4] Free-to-move without power
[5] When U-shaped arms only polished stainless steel

DEA DUO 4	ERA 3	ERA DUO 3	ERA 3 GS	ERA DUO 3 GS	ERA 3 GS-U	ERA 3 GATE-BIKE	ERA 4	ERA 4-LE	ERA DUO 4-LE	GLASS 1600	Glass 1800	BASIC 3
-/•	•/-	•/-	-/•	-/•	-/•	•/-	•/-	•/-	•/-	-/•	-/•	•/-
-/•/•	•/-/-	-/•/-	•/-/-	-/•/-	•/-/-	•/-/-	•/-/-	•/-/-	-/•/-	•/-/•	•/-/•	•/-/-
-/-	-/-	-/-	-/-	-/-	-/-	•/-	-/-	-/-	-/-	-/-	-/-	-/-
-/•	•/-	•/-	•/-	•/-	•/-	•/-	-/•	-/•	-/•	•/-	•/-	•/-
•/-	•/-	•/-	•/-	•/-	-/•	•/-	•/-	•/-	•/-	-	-	[3]
2 550 / 100.39"	2 520 / 99.21"	2 520 / 99.21"	2 520 / 99.21"	2 520 / 99.21"	2 520 / 99.21"	2 520 / 99.21"	2 520 / 99.21"	2 520 / 99.21"	2 520 / 99.21"	2 450 / 96.46"	2 450 / 96.46"	2 435 / 95.87"
2 235 / 88.00"	1 540 / 60.63"	2 360 / 92.91"	1 540 / 60.63"	2 360 / 92.91"	1 540 / 60.63"	2 230 / 87.80"	1 540 / 60.63"	1 350 / 53.15"	2 050 / 80.71"	1 610 / 63.39"	1 810 / 71.26"	1 385 / 54.53"
2 100 / 82.68"	2 100 / 82.68"	2 100 / 82.68"	2 100 / 82.68"	2 100 / 82.68"	2 100 / 82.68"	2 100 / 82.68"	2 100 / 82.68"	2 100 / 82.68"	2 100 / 82.68"	2 050 / 80.71"	2 050 / 80.71"	2 040 / 80.31"
550 / 21.65"	644 / 25.35"	644 / 25.35"	644 / 25.35"	644 / 25.35"	644 / 25.35"	644 / 25.35"	535 / 21.06"	550 / 21.63"	550 / 21.63"	705 / 27.76"	805 / 31.69"	648 / 25.51"
-	-	-	-	-	-	540 / 21.26"	-	-	-	-	-	-
-	•	•	•	•	•	•	•	•	•	-	-	•
-/•	-/-	-/-	-/-	-/-	-/-	-/-	-/-	-/-	-/-	-/-	-/-	-/-
-	-	-	•	•	•	-	-	-	-	•	•	-
-/•	•/-	•/-	•/-	•/-	•/-	•/-	•/-	•/-	•/-	-/•	-/•	•/-
-/•	•/-	•/-	•/-	•/-	-/•	•/-	•/-	•/-	•/-	-/-	-/-	•/-
•/•	•/•	•/•	•/•	•/•	•/•	•/•	•/•	•/•	•/•	•/•	•/•	•/•
-	-	-	-	-	-	•	-	-	-	-	-	-
•/•	•/•	•/•	•/•	•/•	•/•	•/•	•/•	•/•	•/•	•/•	•/•	•/•
•/•/•	•/•/•	•/•/•	•/•/•	•/•/•	•/•/•	•/•/•	•/•/•	•/•/•	•/•/•	•/•/•	•/•/•	•/•/•
•	•	•	•	•	•	•	•	•	•	•	•	•
•/•	•/•	•/•	•/•	•/•	•/•	•/•	•/•	•/•	•/•	•/•	•/•	•/•
-	•	•	•	•	•	•	•	•	•	-	-	-
•/•	•/•	•/•	•/•	•/•	•/•	•/•	•/•	•/•	•/•	•/•	•/•	•/•
•	•	•	•	•	•	•	•	•	•	•	•	•
•	•	•	•	•	-	•	•	•	•	-	-	•
•/•	•/•	•/•	•/•	•/•	•/•	•/•	•/•	•/•	•/•	•/•	•/•	•/•
•/•	•/•	•/•	•/•	•/•	•/•	•/•	•/•	•/•	•/•	•/•	•/•	•/•
•	•	•	•	•	•	•	•	•	•	•	•	•
-	•	•	•	•	•	•	•	•	•	-	-	-
•	•	•	•	•	•	•	•	•	•	•	•	•
•/•	•/•	•/•	•/•	•/•	•/•	•/•	•/•	•/•	•/•	•/•	•/•	•/•
-/-	•/•	•/•	•/•	•/•	•/•	•/•	•/•	•/•	•/•	-/-	-/-	•/•
•	-	-	-	-	-	-	-	-	-	-	-	-
•/•	•/•	•/•	•/•	•/•	[5]	•/•	•/•	•/•	•/•	-	-	•/•

[6] 230 VAC for Raxon-DEA turnstiles is available just in stainless steel option
 [7] Max passage width for full-height gate: 920 mm / 36.22"

Turnstile Model GATE

GATE DEA



GATE DEA DUO



GATE DEA-U



GATE DEA DUO-U



Type	GATE DEA	GATE DEA DUO	GATE DEA-U	GATE DEA DUO-U
Motorized full height gate	•	•	•	•
Single version / Double version	• / -	- / •	• / -	- / •
Barrier type				
11 straight arms [1] / 6 trombone style (U-shaped) arms [2]	• / -	• / -	- / •	- / •
Dimensions				
Unit height in mm / inches	2 465 / 9705*	2 465 / 9705*	2 465 / 9705*	2 465 / 9705*
Unit width in mm / inches for passage width single 900 mm / 35.43* / double 1650 mm / 64.96*	1 450 / 5709*	2 570 / 101.18*	1 450 / 5709*	2 570 / 101.18*
Passage height in mm / inches	2 100 / 82.68*	2 100 / 82.68*	2 100 / 82.68*	2 100 / 82.68*
Max passage width in mm / inches	max. 920 / 36.22*	max. 1 800 / 70.87*	max. 920 / 36.22*	max. 1 800 / 70.87*
Standard material				
ERA version - frame: hot dip zinc galvanized	-	-	-	-
DEA version - casework: hot dip zinc galvanized with RAL powder coated finish	•	•	•	•
Top panel (roof): hot dip zinc galvanized with RAL powder coated finish	•	•	•	•
Barrier: hot dip zinc galvanized with plastic covering caps / polished stainless steel	• / -	• / -	- / •	- / •
Safety features				
Emergency (Fire Alarm) input / Go Call function	• / -	• / -	• / -	• / -
Induction loop system for detection of bicycles and scooters	-	-	-	-
Communication interface				
Relay Inputs / Outputs	• / •	• / •	• / •	• / •
RS485 / USB / Ethernet	• / • / •	• / • / •	• / • / •	• / • / •
Drive mechanism				
Fail-Safe [3]	•	•	•	•
Operating environment				
Indoor / Outdoor	• / •	• / •	• / •	• / •
Extreme weather conditions *	-	-	-	-
Power supply input				
24 VAC / 230 VAC [4]	• / •	• / •	• / •	• / •
Backup battery *	•	•	•	•
Optional features				
Heel protector	•	•	-	-
RFID reader bracket / Identification or Ticket terminal bracket	• / •	• / •	• / •	• / •
Access Light / Lane Light including bracket	• / •	• / •	• / •	• / •
Ceiling Light	•	•	•	•
Canopy LT	-	-	-	-
Optional remote control systems				
Remote control console (EasyTouch, TouchPanel)	•	•	•	•
TMON software application (remote control from any PC) / Passage Scheduler (automatic planner)	• / •	• / •	• / •	• / •
Optional finishes				
ERA version - frame and top panel: RAL powder coated finish / stainless steel	-	-	-	-
DEA version - casework and roof: RAL powder coated finish / stainless steel	• / •	• / •	• / •	• / •
Barrier: RAL powder coated finish / brushed stainless steel	• / •	• / •	[5]	[5]

• Available
- Not available

* Optional accessories
[1] ø 40 mm / 1.57" with plastic covering caps

[2] ø 22 mm / 0.87"
[3] Free-to-move without power

[4] 230 VAC for REXON-DEA turnstiles is available just in stainless steel option
[5] When U-shaped arms only polished stainless steel

GATE ERA



GATE ERA DUO



GATE ERA-U



GATE ERA DUO-U



GATE ERA LE



GATE ERA DUO LE



GATE ERA LE-U



GATE ERA DUO LE-U



•	•	•	•	•	•	•	•
•/-	-/•	•/-	-/•	•/-	-/•	•/-	-/•
•/-	•/-	-/•	-/•	•/-	•/-	-/•	-/•
2 520 / 99.21"	2 520 / 99.21"	2 520 / 99.21"	2 520 / 99.21"	2 520 / 99.21"	2 520 / 99.21"	2 520 / 99.21"	2 520 / 99.21"
1 020 / 40.16"	2 090 / 82.28"	1 020 / 40.16"	2 090 / 82.28"	1 240 / 48.82"	2 410 / 94.88"	1 240 / 48.82"	2 410 / 94.88"
2 100 / 82.68"	2 100 / 82.68"	2 100 / 82.68"	2 100 / 82.68"	2 100 / 82.68"	2 100 / 82.68"	2 100 / 82.68"	2 100 / 82.68"
max. 920 / 36.22"	max. 1 800 / 70.87"	max. 920 / 36.22"	max. 1 800 / 70.87"	max. 920 / 36.22"	max. 1 800 / 70.87"	max. 920 / 36.22"	max. 1 800 / 70.87"
•	•	•	•	•	•	•	•
-	-	-	-	-	-	-	-
•	•	•	•	•	•	•	•
•/-	•/-	-/•	-/•	•/-	•/-	-/•	-/•
•/-	•/-	•/-	•/-	•/-	•/-	•/-	•/-
-	-	-	-	-	-	-	-
•/•	•/•	•/•	•/•	•/•	•/•	•/•	•/•
•/•/•	•/•/•	•/•/•	•/•/•	•/•/•	•/•/•	•/•/•	•/•/•
•	•	•	•	•	•	•	•
•/•	•/•	•/•	•/•	•/•	•/•	•/•	•/•
•	•	•	•	•	•	•	•
•/•	•/•	•/•	•/•	•/•	•/•	•/•	•/•
•	•	•	•	•	•	•	•
•	•	-	-	•	•	-	-
•/•	•/•	•/•	•/•	•/•	•/•	•/•	•/•
•/•	•/•	•/•	•/•	•/•	•/•	•/•	•/•
•	•	•	•	•	•	•	•
•	•	•	•	•	•	•	•
•	•	•	•	•	•	•	•
•/•	•/•	•/•	•/•	•/•	•/•	•/•	•/•
•/•	•/•	•/•	•/•	•/•	•/•	•/•	•/•
-	-	-	-	-	-	-	-
•/•	•/•	[5]	[5]	•/•	•/•	[5]	[5]

Options & Accessories



TMON SOFTWARE – software application for easy remote control of the turnstiles and gates



EASY::TOUCH – turnstile remote control console with an intuitive graphical user interface



TOUCH PANEL – touch-button panel for remote control of turnstiles and gates

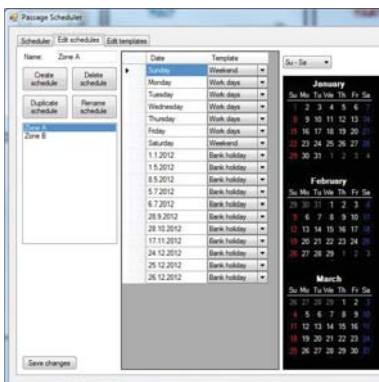

TURNSTILE SCHEDULER – software for automatic time programming of turnstile accessibility in each direction (TMON SW required)



ACCESS LIGHT WITH BRACKET – access control light with integrated RFID bracket including bracket



LANE LIGHT – front mounted lane accessibility light panel



CEILING LIGHT – with automatic Day-On/Night-Off mode to illuminate the walkway



HEEL PROTECTOR – protector of straight arms made of black toughened rubber material



RFID READER – implementation of any RFID reader



CANOPY LT/CANOPY LT DUO – single version for REXON ERA / GATE ERA or duo version for REXON ERA DUO / GATE ERA DUO made from Aluminium frame and polycarbonate panels



MOUNTING FRAME – console suitable for REXON and GATE models for pre-installation into concerted basement



ALTERNATIVE SURFACE FINISH – frame, rotor, arms, central pillar or completely in stainless steel or Polyester Powder Coated



INDUCTIVE LOOP SYSTEM – detects bicycle or small motor-scooter in passage lane



ALARM BUZZER – alarm buzzer signalling unauthorized passage



EXTREME OUTDOOR PACKAGE – special package for outdoor application (heating module + IP protection)



WAV PLAYER – sound signaling device for audio confirmation of turnstile operation mode



REXON::TICKET – external implementation of identification terminal



PUSHBAR – Push-Bars on glass wing for REXON GLASS turnstile

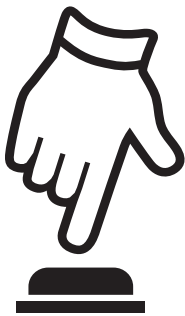

SWITCH-BUTTON – for manual gate control



REXON NET – stainless steel net barriers for application where the highest level of security is required. Used in a risky environment such as laboratories, prisons, etc.



ed. VIII-2017

Specifications are subject to change without prior notice.



COMINFO, a.s.

Nabrezi 695, 760 01 Zlin - Prstne, Czech Republic

T +420 603 151 333

cominfo@cominfo.cz

www.cominfo.eu

cominfo
security first